



## TYPICAL MOTOR PERFORMANCE DATA

Model: MNET02006D2TBR

Serie: NEMA Elite

Issued Date	11/14/2022	Doc. #	390-R0
Issued By	LD	Issued Rev	0

HP	kW	Pole	FL RPM	Frame	Voltage	Hz	Phase	FL Amps
200.00	150.00	6	1190	S449T	460	60	3	232
Enclosure	IP	Ins. Class	S.F.	Duty	Nom. Eff.	Nema Design	kVA Code	Ambient Temp. (°C)
TEFC	54	F (*)	1.15	CONT	95.8	B	G	40 C

\* Inverter Duty

Load	HP	kW	Amperes	Efficiency (%)	Power Factor (%)
Full Load	200.00	150.00	232.0	95.6	84.4
¾ Load	150.00	111.90	178.0	94.8	83.1
½ Load	100.00	74.60	128.0	92.8	78.3
¼ Load	50.00	37.30	86.0	86.9	62.4
No Load			63.9		5.4
Locked Rotor			1450.0		20.3

### Torque

Full Load (lb-ft)	Locked Rotor (% FLT)	Pull Up (% FLT)	Break Down (% FLT)	Rotor Inertia (lb-ft²)
883.00	135.0	105.0	250.0	173.05

Safe Stall Time(s) Cold / Hot	Sound Pressure dB(A) @ 1M	Bearings*		Approx. Motor Weight (lbs)
		DE	NDE	
35 / 15	82	-	6322C3	6318C3

\*Bearings are the only recommended spare part(s).

### Included Accessories:

All characteristics are average expected values.

Engineering		Doc. Written By		Doc.# / Rev	MNET02006D2TBR
Engr. Date		Doc. Approved By		Doc. Issued	



### SPEED TORQUE/CURRENT CURVE

Model: MNET02006D2TBR

Serie: NEMA Elite

Issued Date	11/14/2022	Doc. #	390-R0
Issued By	LD	Issued Rev	0

HP	kW	Pole	FL RPM	Frame	Voltage	Hz	Phase	FL Amps
200.00	150.00	6	1190	S449T	460	60	3	232
Enclosure	IP	Ins. Class	S.F.	Duty	Nom. Eff.	Nema Design	kVA Code	Ambient Temp. (°C)
TEFC	54	F (*)	1.15	CONT	95.8	B	G	40 C
Locked Rotor Amps	Rotor Inertia (lb-ft <sup>2</sup> )	Torque						
		Full Load (lb-ft)	Locked Rotor (%)	Pull Up (%)	Break Down (%)			
1450.0	173.05	883	135.0	105.0	250.0			

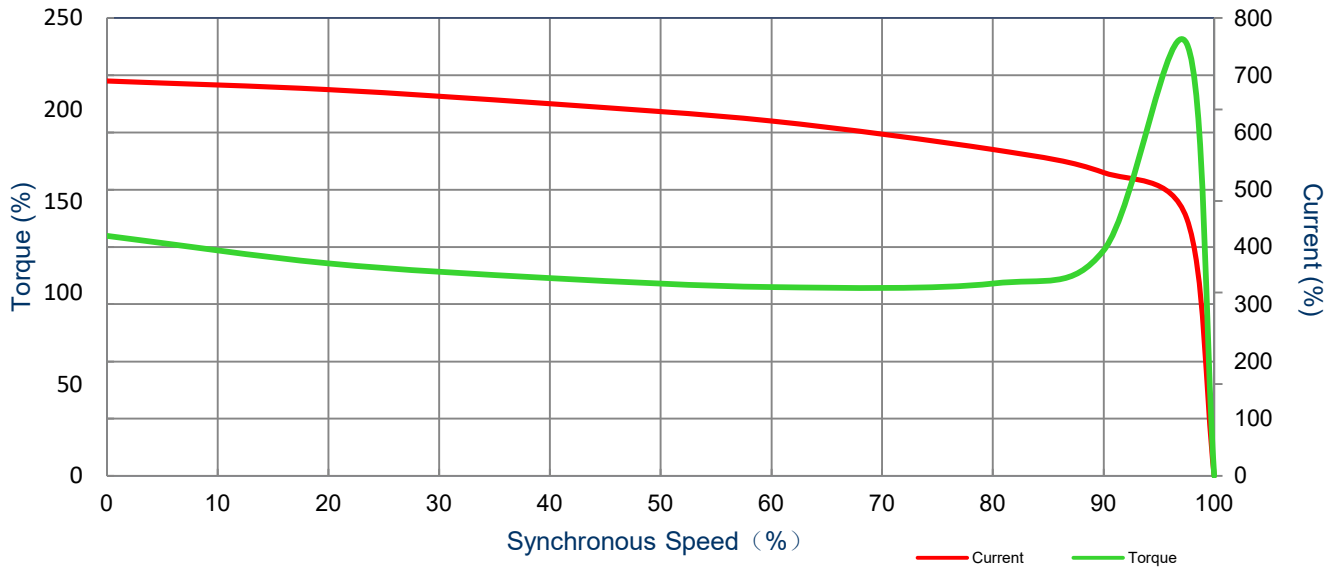

All characteristics are average expected values.

Engineering		Doc. Written By		Doc.# / Rev	MNET02006D2TBR
Engr. Date		Doc. Approved By		Doc. Issued	

Issued Date	11/14/2022	Doc. #	390-R0
Issued By	LD	Issued Rev	0

## Motor Connection Diagram

Model: MNET02006D2TBR

Serie: NEMA Elite

### 6 Leads Connection Diagram

Across the Line Starting / Run - Delta:

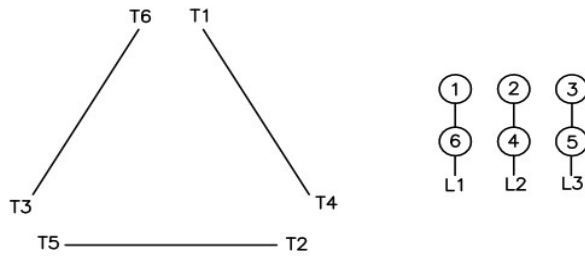

Alternate Starting Connection - Wye:

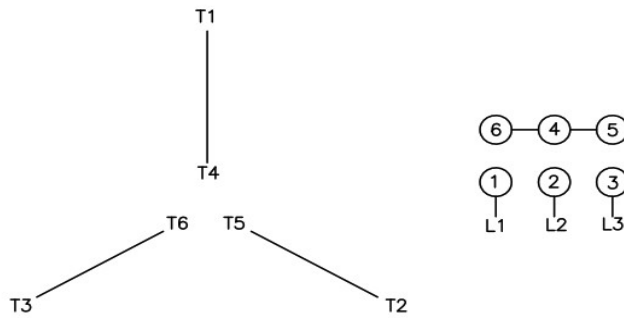

All characteristics are average expected values.

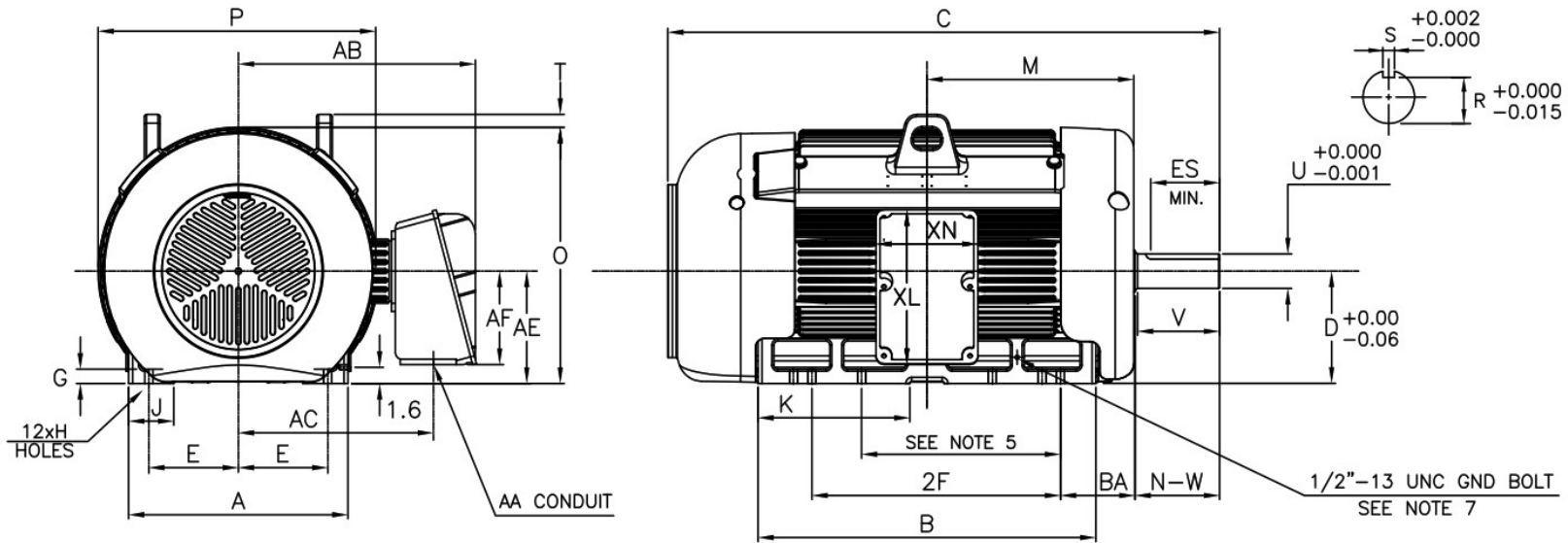

Engineering		Doc. Written By		Doc.# / Rev	MNET02006D2TBR
Engr. Date		Doc. Approved By		Doc. Issued	



UNITS: INCHES

FRAME SIZE	MOTOR DIMENSIONS											CONDUIT BOX						
	A	B	C	D	G	J	K	M	O	P	T	AA[NPT]	AB	AC	AE	AF	XL	XN
S447T/S449T	22.0	34.0	55.5	11.00	1.4	4.5	15.3	20.8	25.0	27.9	1.3	4.00	23.8	19.6	11.00	9.1	15.2	10.2

FRAME SIZE	MOUNTING				SHAFT EXTENSION			KEY SEAT			BEARINGS				MAXIMUM WEIGHT
	E	2F	H	BA	N-W	V	U	R	S	ES	LS ROLLER	LS BALL 6/8P	LS BALL 4P	OS 4~8P	
S447T/S449T	9.00	20.00/25.00	0.82	7.50	8.50	8.25	3.375	2.880	0.875	6.91	NU322C3	6322C3	6318C3	6318C3	XXX lb

<b>Units: inches</b>		<b>PROPRIETARY INFORMATION</b> We reserve all rights in this document and in the information contained therein. Reproduction, use or disclosure to third parties without express authorization is strictly forbidden. Offenders will be held liable for payment of damages.	<b>Notes:</b>		
<b>ROTATION FROM NDE</b>			1. MAIN CONDUIT BOX MAY BE ROTATED IN 90 DEGREE INCREMENTS		
<b>CCW</b>	<b>CW</b>		2. STANDARD PRODUCT USES BI-DIRECTIONAL FAN. OPPOSITE ROTATION AVAILABLE ONLY BY CONNECTION CHANGE.		
					
<b>X</b>					
TASHIDA RESERVES THE RIGHT TO MAKE CHANGES OF TECHNICAL IMPROVEMENT AND THE DATA MAY CHANGE WITHOUT NOTICE				PRELIMINARY	
DO NOT USE FOR CONSTRUCTION, INSTALLATION, OR APPLICATION PURPOSES UNLESS THE DRAWING IS MARKED AS CERTIFIED			X	CERTIFIED	
		<b>TOTALLY ENCLOSED FAN COOLED HORIZONTAL FOOT MOUNTED 3 PHASE INDUCTION MOTOR</b>		Drawing #: MNET02006D2TBR	
				Rev. Date: 11/14/2022	Rev. #: 0
		Standard: NEMA	Mount.: F1		
		Frame: S449T	Per.:	LD	