



TYPICAL MOTOR PERFORMANCE DATA

Model: MNET01254B2TBR

Serie: NEMA Elite

Issued Date	11/14/2022	Doc. #	390-R0
Issued By	LD	Issued Rev	0

HP	kW	Pole	FL RPM	Frame	Voltage	Hz	Phase	FL Amps
125.00	90.00	4	1785	S444T	230/460	60	3	284/142
Enclosure	IP	Ins. Class	S.F.	Duty	Nom. Eff.	Nema Design	kVA Code	Ambient Temp. (°C)
TEFC	55	F (*)	1.15	CONT	95.4	B	F	40 C

* Inverter Duty

Load	HP	kW	Amperes	Efficiency (%)	Power Factor (%)
Full Load	125.00	90.00	142.0	95.8	86.0
¾ Load	93.75	69.90	108.0	95.3	85.2
½ Load	62.50	46.60	76.0	93.9	81.4
¼ Load	31.25	23.30	49.0	89.3	66.4
No Load			36.3		0.0
Locked Rotor			827.0		25.2

Torque				Rotor Inertia
Full Load (lb-ft)	Locked Rotor (% FLT)	Pull Up (% FLT)	Break Down (% FLT)	(lb-ft²)
368.00	150.0	115.0	225.0	54.36

Safe Stall Time(s) Cold / Hot	Sound Pressure dB(A) @ 1M	Bearings*		Approx. Motor Weight (lbs)
		DE	NDE	
35 / 15	84	6318C3	6316C3	0

*Bearings are the only recommended spare part(s).

Included Accessories:

All characteristics are average expected values.

Engineering		Doc. Written By		Doc.# / Rev	MNET01254B2TBR
Engr. Date		Doc. Approved By		Doc. Issued	



SPEED TORQUE/CURRENT CURVE

Model: MNET01254B2TBR

Serie: NEMA Elite

Issued Date	11/14/2022	Doc. #	390-R0
Issued By	LD	Issued Rev	0

HP	kW	Pole	FL RPM	Frame	Voltage	Hz	Phase	FL Amps
125.00	90.00	4	1785	S444T	230/460	60	3	284/142
Enclosure	IP	Ins. Class	S.F.	Duty	Nom. Eff.	Nema Design	kVA Code	Ambient Temp. (°C)
TEFC	55	F (*)	1.15	CONT	95.4	B	F	40 C
Locked Rotor Amps	Rotor Inertia (lb-ft ²)	Torque				Pull Up (%)	Break Down (%)	
		Full Load (lb-ft)	Locked Rotor (%)					
827.0	54.36	368	150.0		115.0	225.0		

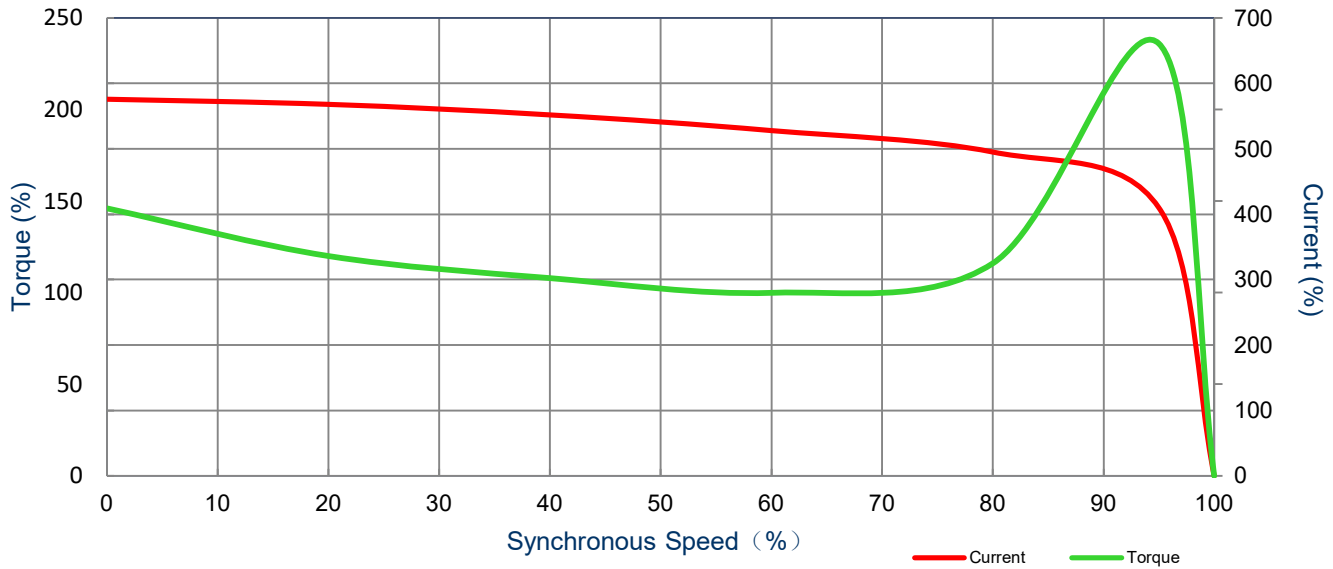

All characteristics are average expected values.

Engineering		Doc. Written By		Doc.# / Rev	MNET01254B2TBR
Engr. Date		Doc. Approved By		Doc. Issued	

Issued Date	11/14/2022	Doc. #	390-R0
Issued By	LD	Issued Rev	0

Motor Connection Diagram

Model: MNET01254B2TBR

Serie: NEMA Elite

12 Leads Connection Diagram

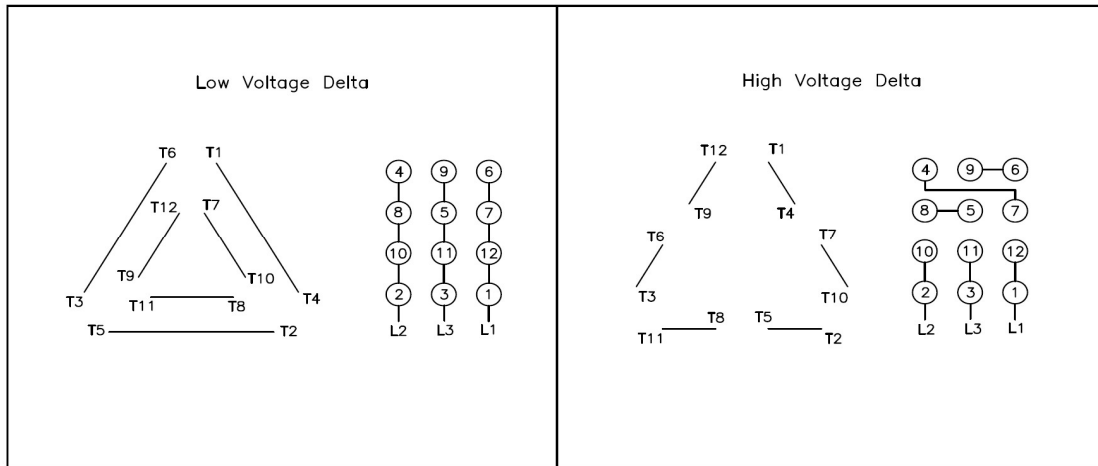

All characteristics are average expected values.

Engineering		Doc. Written By		Doc.# / Rev	MNET01254B2TBR
Engr. Date		Doc. Approved By		Doc. Issued	

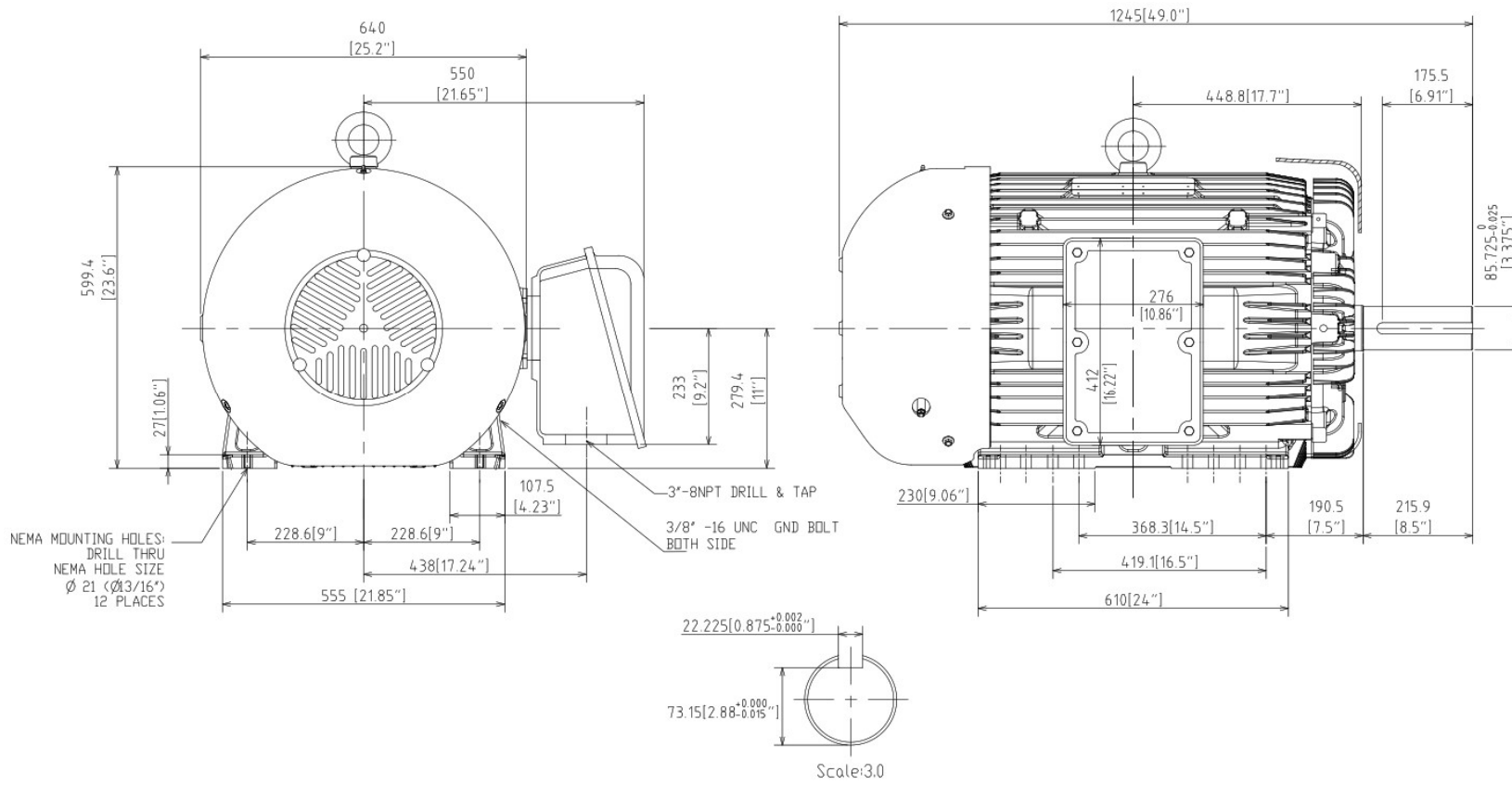

Units: inches		PROPRIETARY INFORMATION We reserve all rights in this document and in the information contained therein. Reproduction, use or disclosure to third parties without express authorization is strictly forbidden. Offenders will be held liable for payment of damages.	Notes:	
ROTATION FROM NDE			1. MAIN CONDUIT BOX MAY BE ROTATED IN 90 DEGREE INCREMENTS	
CCW	CW		2. STANDARD PRODUCT USES BI-DIRECTIONAL FAN. OPPOSITE ROTATION AVAILABLE ONLY BY CONNECTION CHANGE.	
X				
TASHIDA RESERVES THE RIGHT TO MAKE CHANGES OF TECHNICAL IMPROVEMENT AND THE DATA MAY CHANGE WITHOUT NOTICE				PRELIMINARY
DO NOT USE FOR CONSTRUCTION, INSTALLATION, OR APPLICATION PURPOSES UNLESS THE DRAWING IS MARKED AS CERTIFIED			X	CERTIFIED
<h1>Tashida</h1>	TOTALLY ENCLOSED FAN COOLED HORIZONTAL FOOT MOUNTED 3 PHASE INDUCTION MOTOR		Drawing #: MNET01254B2TBR	
			Rev. Date: 11/14/2022	Rev. #: 0
	Standard: NEMA	Mount.: F1		
	Frame: S444T/5T	Per.:	LD	