



TYPICAL MOTOR PERFORMANCE DATA

Model: MEGP01X16E2TBL

Serie: IEC Graphene

Issued Date	11/14/2022	Doc. #	382-R0
Issued By	LD	Issued Rev	0

HP	kW	Pole	FL RPM	Frame	Voltage	Hz	Phase	FL Amps
1.5	1.1	6	1122	90L	230/460	60	3	4.69 /2.34
Enclosure	IP	Ins. Class	S.F.	Duty	Nom. Eff.	IEC Design	kVA Code	Ambient Temp. (°C)
TEFC	55	F (*)	1.15	S1	IE2-85.5	N	-	40

* Inverter Duty

Load	HP	kW	Amperes	Efficiency (%)	Power Factor (%)
Full Load	1.5	1.1	2.4	85.6	70.5
¾ Load	1.125	0.825	2.1	85.3	61.5
½ Load	0.75	0.55	1.8	83.1	48.0
¼ Load	0.375	0.275	1.6	75.0	29.3
No Load			1.6		16.0
Locked Rotor			15.9		0.2

Torque				Rotor Inertia
Full Load (N-m)	Locked Rotor (% FLT)	Pull Up (% FLT)	Break Down (% FLT)	(Kg-m²)
9.36	328.0	327.3	352.2	0.00714

Safe Stall Time(s) Cold / Hot	Sound Pressure dB(A) @ 1M	Bearings*		Approx. Motor Weight (kg)
		DE	NDE	
27.3/11.1	-	6205/2Z C3	6203/2Z C3	26

*Bearings are the only recommended spare part(s).

Included Accessories:
PTC Thermistor

All characteristics are average expected values.

Engineering		Doc. Written By		Doc.# / Rev	MEGP01X16E2TBL
Engr. Date		Doc. Approved By		Doc. Issued	



Issued Date	11/14/2022	Doc. #	382-R0
Issued By	LD	Issued Rev	0

SPEED TORQUE/CURRENT CURVE

Model: MEGP01X16E2TBL

Serie: IEC Graphene

HP	kW	Pole	FL RPM	Frame	Voltage	Hz	Phase	FL Amps
1.5	1.1	6	1122	90L	230/460	60	3	4.69 /2.34
Enclosure	IP	Ins. Class	S.F.	Duty	Nom. Eff.	IEC Design	kVA Code	Ambient Temp. (°C)
TEFC	55	F (*)	1.15	S1	IE2-85.5	N	-	40
Locked Rotor Amps	Rotor Inertia (Kg-m2)	Torque				Pull Up (%)	Break Down (%)	
		Full Load (N-m)	Locked Rotor (%)					
15.9	0.00714	9.36	328.0		327.3		352.2	

Current vs Slip Curve and Torque vs Slip Curve

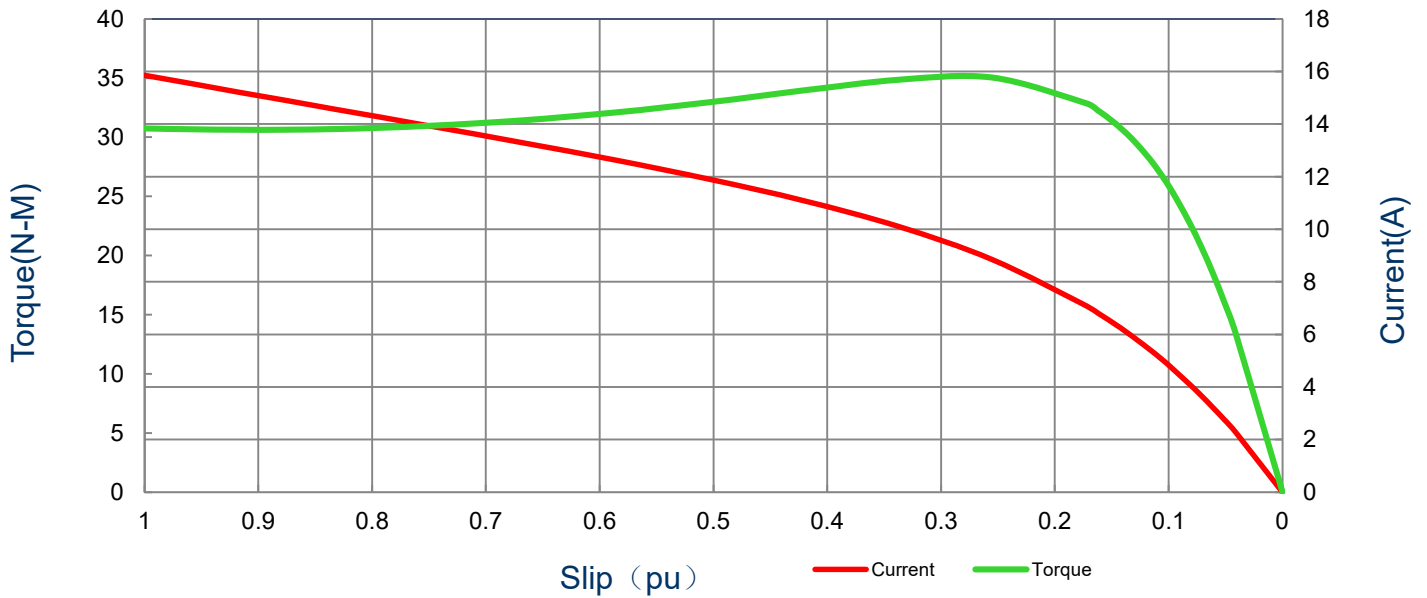

All characteristics are average expected values.

Engineering		Doc. Written By		Doc.# / Rev	MEGP01X16E2TBL
Engr. Date		Doc. Approved By		Doc. Issued	

Issued Date	11/14/2022	Doc. #	382-R0
Issued By	LD	Issued Rev	0

Motor Connection Diagram

Model: MEGP01X16E2TBL

Serie: IEC Graphene

HP	kW	Pole	FL RPM	Frame	Voltage	Hz	Phase	FL Amps
1.5	1.1	6	1122	90L	230/460	60	3	4.69 /2.34
Enclosure	IP	Ins. Class	S.F.	Duty	Nom. Eff.	IEC Design	kVA Code	Ambient Temp. (°C)
TEFC	55	F (*)	1.15	S1	IE2-85.5	N	-	40

9 Leads Connection Diagram

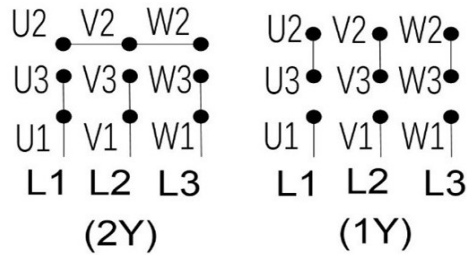

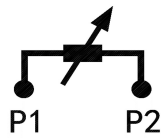

PTC Diagram

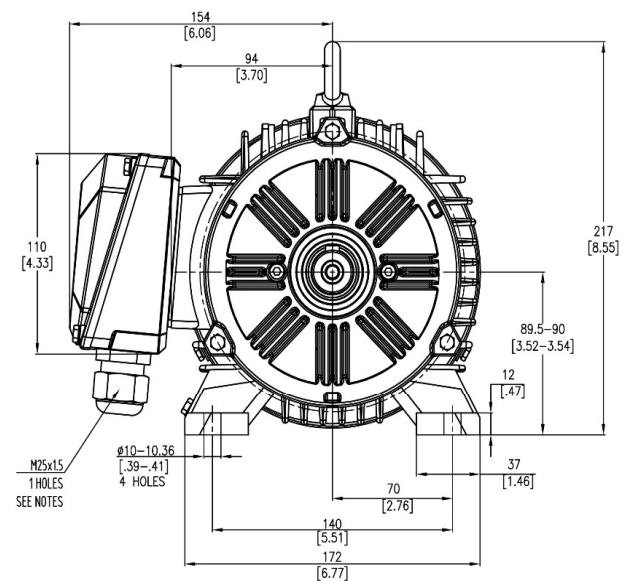
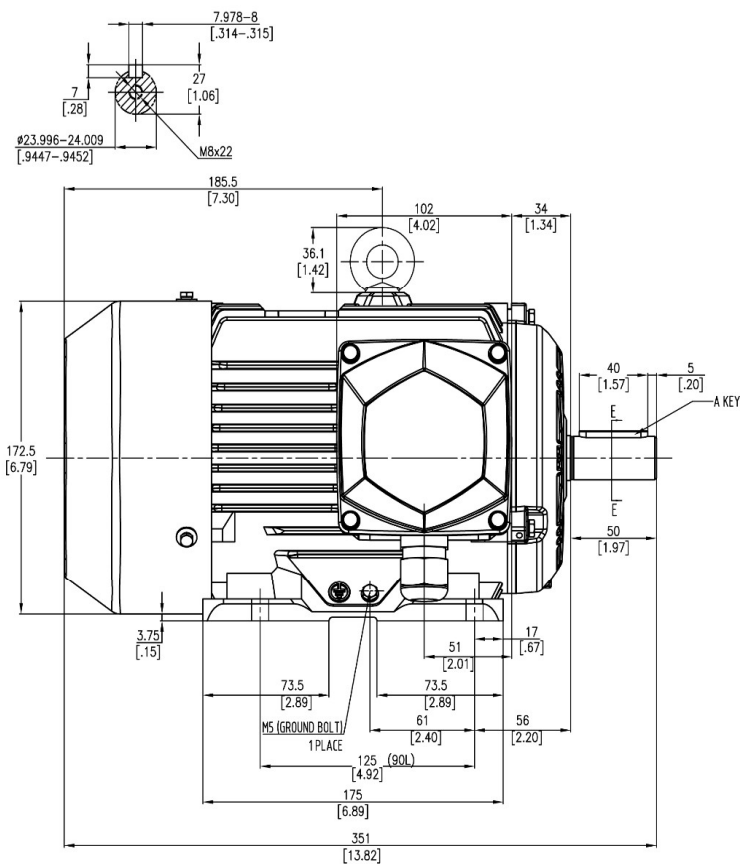

All characteristics are average expected values.

Engineering		Doc. Written By		Doc.# / Rev	MEGP01X16E2TBL
Engr. Date		Doc. Approved By		Doc. Issued	



Units: mm (in)		PROPRIETARY INFORMATION We reserve all rights in this document and in the information contained therein. Reproduction, use or disclosure to third parties without express authorization is strictly forbidden. Offenders will be held liable for payment of damages.	Notes:		
ROTATION FROM DE			1. MAIN CONDUIT BOX MAY BE ROTATED IN 90 DEGREE INCREMENTS		
CCW	CW		2. STANDARD PRODUCT USES BI-DIRECTIONAL FAN. OPPOSITE ROTATION		
			AVAILABLE ONLY BY CONNECTION CHANGE.		
	X				
TASHIDA RESERVES THE RIGHT TO MAKE CHANGES OF TECHNICAL IMPROVEMENT AND THE DATA MAY CHANGE WITHOUT NOTICE			PRELIMINARY		
DO NOT USE FOR CONSTRUCTION, INSTALLATION, OR APPLICATION PURPOSES UNLESS THE DRAWING IS MARKED AS CERTIFIED			X CERTIFIED		
<h1>Tashida</h1>		TOTALLY ENCLOSED FAN COOLED HORIZONTAL FOOT MOUNTED 3 PHASE INDUCTION MOTOR		Drawing #: MEGP01X16E2TBL	
				Rev. Date: 11/14/2022 Rev. #: 0	
		Standard: IEC-60034		Mount.: IMB3	
		Frame 90L LHS		Per.: LD	