



TYPICAL MOTOR PERFORMANCE DATA

Model: MEGP00036E3TBL

Serie: IEC Graphene

Issued Date	11/14/2022	Doc. #	382-R0
Issued By	LD	Issued Rev	0

HP	kW	Pole	FL RPM	Frame	Voltage	Hz	Phase	FL Amps
4	3	6	1152	132S	230/460	60	3	12.05/6.03
Enclosure	IP	Ins. Class	S.F.	Duty	Nom. Eff.	IEC Design	kVA Code	Ambient Temp. (°C)
TEFC	55	F (*)	1.15	S1	IE3-89.5	N	-	40

* Inverter Duty

Load	HP	kW	Amperes	Efficiency (%)	Power Factor (%)
Full Load	4	3	6.0	89.5	73.5
¾ Load	3	2.25	5.0	89.8	65.8
½ Load	2	1.5	4.2	89.0	52.7
¼ Load	1	0.75	3.7	84.2	31.9
No Load			3.4		14.9
Locked Rotor			35.9		0.1

Torque				Rotor Inertia
Full Load (N-m)	Locked Rotor (% FLT)	Pull Up (% FLT)	Break Down (% FLT)	(Kg-m²)
24.9	211.9	199.8	263.2	0.027

Safe Stall Time(s) Cold / Hot	Sound Pressure dB(A) @ 1M	Bearings*		Approx. Motor Weight (kg)
		DE	NDE	
37.4/15.2	-	6208/2Z C3	6305/2Z C3	56

*Bearings are the only recommended spare part(s).

Included Accessories:
PTC Thermistor

All characteristics are average expected values.

Engineering		Doc. Written By		Doc.# / Rev	MEGP00036E3TBL
Engr. Date		Doc. Approved By		Doc. Issued	



Issued Date	11/14/2022	Doc. #	382-R0
Issued By	LD	Issued Rev	0

SPEED TORQUE/CURRENT CURVE

Model: MEGP00036E3TBL

Serie: IEC Graphene

HP	kW	Pole	FL RPM	Frame	Voltage	Hz	Phase	FL Amps
4	3	6	1152	132S	230/460	60	3	12.05/6.03
Enclosure	IP	Ins. Class	S.F.	Duty	Nom. Eff.	IEC Design	kVA Code	Ambient Temp. (°C)
TEFC	55	F (*)	1.15	S1	IE3-89.5	N	-	40
Locked Rotor Amps	Rotor Inertia (Kg-m2)	Torque				Pull Up (%)	Break Down (%)	
		Full Load (N-m)	Locked Rotor (%)					
35.88	0.027	24.9	211.9		199.8	263.2		

Current vs Slip Curve and Torque vs Slip Curve

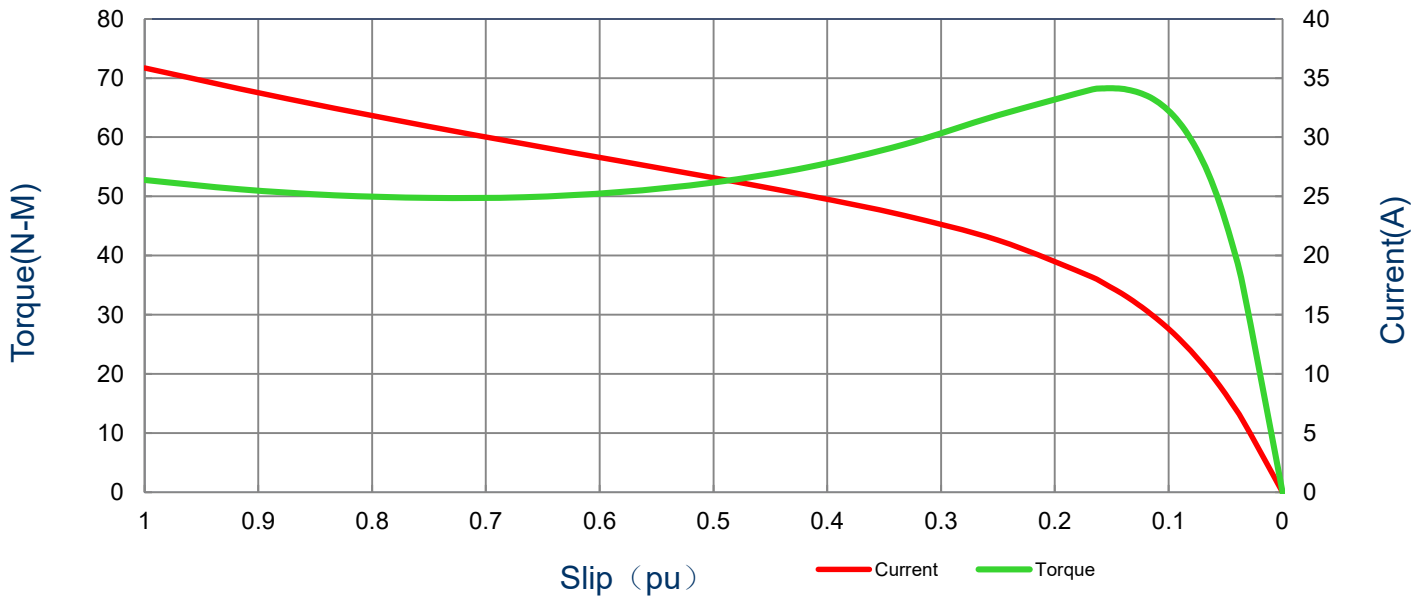

All characteristics are average expected values.

Engineering		Doc. Written By		Doc.# / Rev	MEGP00036E3TBL
Engr. Date		Doc. Approved By		Doc. Issued	

Issued Date	11/14/2022	Doc. #	382-R0
Issued By	LD	Issued Rev	0

Motor Connection Diagram

Model: MEGP00036E3TBL

Serie: IEC Graphene

HP	kW	Pole	FL RPM	Frame	Voltage	Hz	Phase	FL Amps
4	3	6	1152	132S	230/460	60	3	12.05/6.03
Enclosure	IP	Ins. Class	S.F.	Duty	Nom. Eff.	IEC Design	kVA Code	Ambient Temp. (°C)
TEFC	55	F (*)	1.15	S1	IE3-89.5	N	-	40

9 Leads Connection Diagram

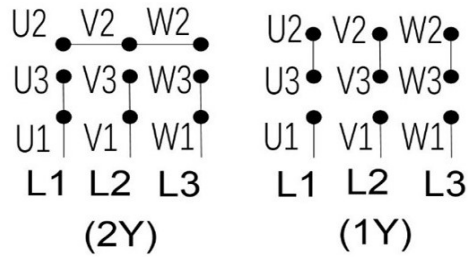

Y- Only Start

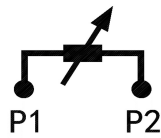

PTC Diagram

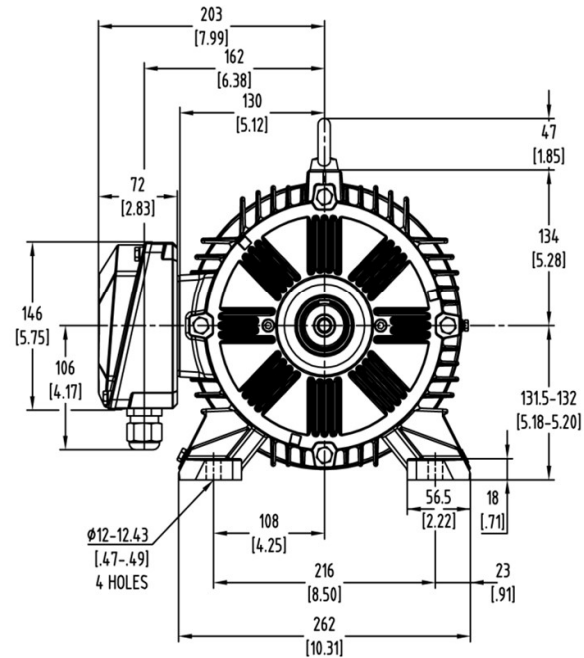
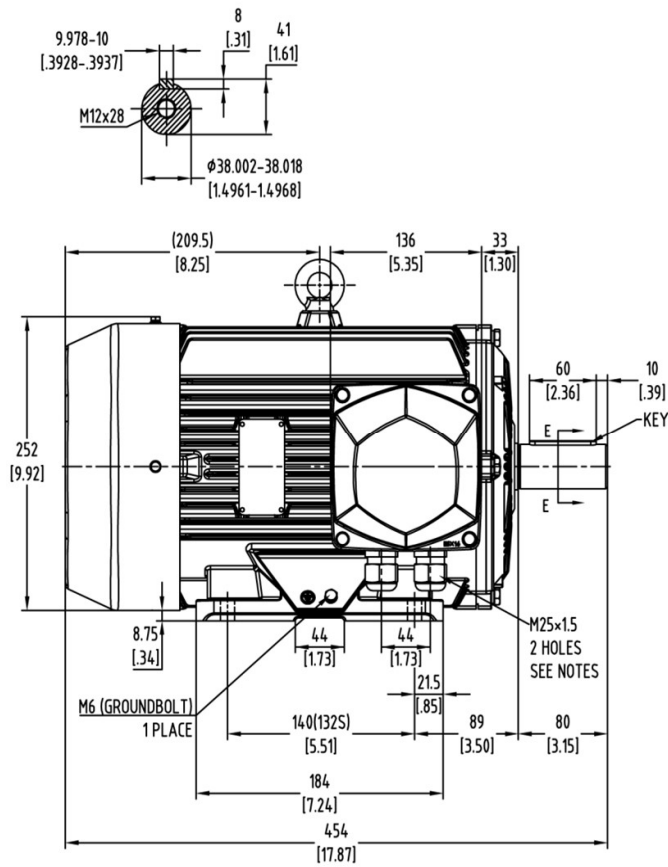

All characteristics are average expected values.

Engineering		Doc. Written By		Doc.# / Rev	MEGP00036E3TBL
Engr. Date		Doc. Approved By		Doc. Issued	



Units: mm (in)		PROPRIETARY INFORMATION We reserve all rights in this document and in the information contained therein. Reproduction, use or disclosure to third parties without express authorization is strictly forbidden. Offenders will be held liable for payment of damages.	Notes:				
ROTATION FROM DE			1. MAIN CONDUIT BOX MAY BE ROTATED IN 90 DEGREE INCREMENTS				
CCW	CW		2. STANDARD PRODUCT USES BI-DIRECTIONAL FAN. OPPOSITE ROTATION				
			AVAILABLE ONLY BY CONNECTION CHANGE.				
	X						
TASHIDA RESERVES THE RIGHT TO MAKE CHANGES OF TECHNICAL IMPROVEMENT AND THE DATA MAY CHANGE WITHOUT NOTICE				PRELIMINARY			
DO NOT USE FOR CONSTRUCTION, INSTALLATION, OR APPLICATION PURPOSES UNLESS THE DRAWING IS MARKED AS CERTIFIED				X CERTIFIED			
<h1>Tashida</h1>		TOTALLY ENCLOSED FAN COOLED HORIZONTAL FOOT MOUNTED 3 PHASE INDUCTION MOTOR		Drawing #: MEGP00036E3TBL			
				Rev. Date: 11/14/2022		Rev. #: 0	
				Standard: IEC-60034		Mount.: IMB3	
		Frame	132S	LHS	Per.: LD		